

PRODUCT DATA SHEET

BIA-BPT-60H • 811181



PRODUCT DETAILS

A pressure tank is engineered to optimize the performance of your pressure pumping system by storing a volume of pressurised water.

This increases the draw-down in the case of small water demand or leaks thus saving your pump from excessive starts and stops.

A pressure tank protects and extends the life of your pump and will reduce noise and needless power consumption.

BRAND

**BIANCO
PUMPZ**

FEATURES

- 4 bar nitrogen pre-charge
- Cold rolled carbon steel construction
- Butyl rubber diaphragm
- Food grade polypropylene liner
- 1" BSPM Tapered 304 grade SS inlet

TECHNICAL DATA

PRESSURE RATING	10 bar
MAXIMUM GAS PRESSURE	5.5 bar
MAXIMUM TEMPERATURE	90°C
TOTAL TANK VOLUME (L)	60
NETT ACCEPTANCE VOLUME (L)	20
NETT WEIGHT (KG)	9.9

DIMENSIONS

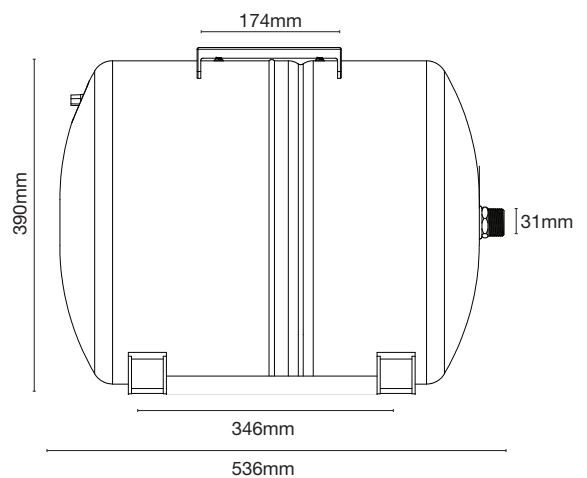

WARRANTY / CERTIFICATIONS

